

# GASSHIELD® HIFLOW™ SANDWICH FILTER 1.5nm FILTRATION

**mott**  
MISSION CRITICAL PRECISION

## Point-of-Use Sandwich Filter in Stainless Steel & Alloy 22 Filter Media

Industry's first point-of-use 'Sandwich-style' filter with metal fiber media

- Mott High Purity Gas Filters provide >9-log filtration of particles up to parts per trillion (PPT) efficiency, for particles as small as 1.5nm to ensure exceptionally clean gas.
- GasShield® Hiflow™ Sandwich Filters offer maximum filtration efficiency, exceptional strength, and reliable performance.
- Designed for Ultra High Purity (UHP) gas delivery applications, these filters provide a compact solution with low pressure drop and minimal part-to-part variability.

## Applications

UHP corrosive gas filtration for: gas sticks for equipment hookup, valve manifold boxes, gas cabinets, tool isolation gas boxes, on-board OEM tool gas boxes.

## Flow Data

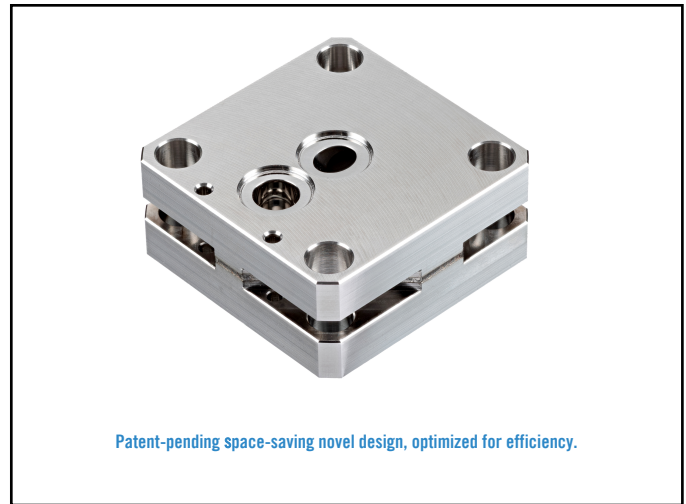
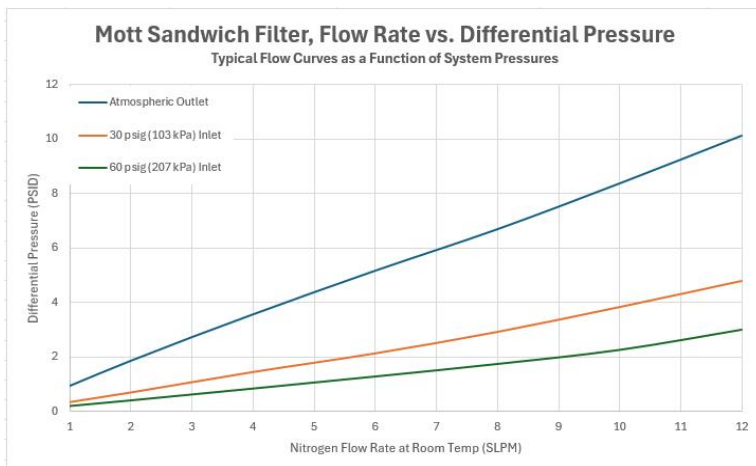

## Materials

- » Hardware: 316L SS or Alloy 22
- » Filter Medium: 316L SS or Alloy 22
- » Wetted Hardware Surface Finish: UHP, Electro-polished

## Operating Conditions

- » Maximum Operating Pressure: >750 psig (51.7 barg)
- » Maximum Operating Temperature for Inert Gas: 460°C
- » Maximum Differential Pressure: 1000 psid (68.9 bar)

## Performance Analysis

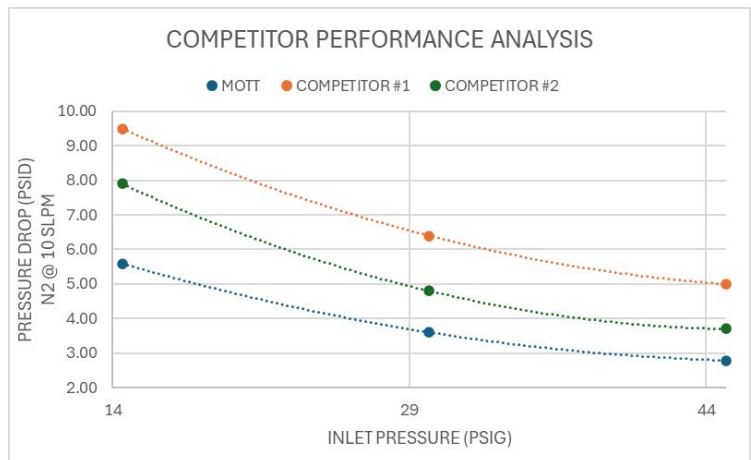

Mott pressure drop lower by at least 25%

# SPECIFICATIONS

Pressure Drop Variance:	+/- 2%
Particle removal size	≥ 0.0015 μm
Filter Efficiency (Log Reduction Value):	>9 LRV (99.9999999% reduction in particles), confirmed at the most penetrating particle size of 0.08 μm, as per the SEMI F38-0720 test method.
Helium Leak Rating:	1 x 10 <sup>-9</sup> atm cc/sec
Moisture Contribution:	<10 ppb after 1 hour of low-flow ambient purge, as per the SEMI F27 test method.
Total Hydrocarbons:	Below detectable limits per SEMI-SPEC 90120396B test method
Particle Shedding:	Zero particle contribution above background (<1 particle/ft <sup>3</sup> ) per SEMI F43-0308 test method

**Warranty:**

Mott Corporation ("Mott") warrants that its GasShield® HiFlow™ sandwich filters will meet the specified retention and media integrity standards for a period of five years from the date of purchase, provided the filter is properly installed and used in accordance with the specified flow, pressure, temperature, and chemical compatibility guidelines published by Mott.

Mott will either replace the filter or grant a refund of the purchase price for any GasShield® HiFlow™ sandwich filter that proves defective under the terms of this limited warranty. No other remedies apply.

Mott disclaims all other warranties, whether expressed or implied, including any warranty of merchantability or fitness for a particular purpose. Mott shall not be liable for consequential, incidental, special, or punitive damages, including but not limited to lost profits, savings, production, or damage to other materials.

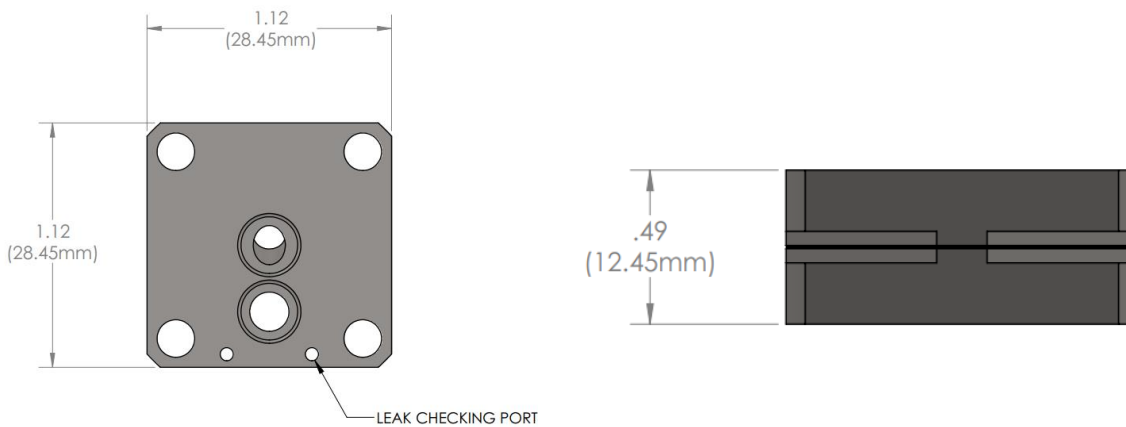

# ORDERING INFORMATION

Material	Part Description	Part Number	Fitting Type	Width	Length	Height
316L SS	6700S-1.120-.490-01	6700065	C-Seal	1.12" (28.45mm)	1.12" (28.45mm)	0.49" (12.45mm)
Alloy 22	6700S-1.120-.490-1E	6700066	C-Seal	1.12" (28.45mm)	1.12" (28.45mm)	0.49" (12.45mm)

\*W-Seal and custom designs/ fittings available. Contact a Mott representative for more information.