

GASSHIELD® DIFFUSER SERIES STAINLESS STEEL FILTER MEDIA

mott
MISSION CRITICAL PRECISION

GasShield® Diffusers guarantee durability up to **3 MILLION CYCLES** and the **INDUSTRY BEST PARTICLE CAPTURE AT 1.5NM**

DESCRIPTION

Mott GasShield® Diffusers quickly vent vacuum chambers to atmosphere which decreases cycle time and increases throughput. Mott diffusers provide uniform and laminar gas flows without disturbing particles in the chamber. These diffusers also remove particles greater than 0.0015 μm from incoming gas minimizing defects on the wafer. They can withstand higher operating pressures and maintain product integrity for over 3,000,000 cycles.

APPLICATIONS

Mott diffusers are used in vent applications on load lock chambers, transfer chambers, cooling chambers, and process chambers of Semiconductor equipment interfaces (CVD, PVD, Etch, Epi) or other vacuum chambers where large volumes of gas flows are required in a short amount of time.

CONNECTIONS

- » Inlet: ¼" Male VCR
- » Outlet: ISO NW40 (Designed for bulkhead mount with standard ISO bulkhead clamps)
- » O-Ring Material: Viton
- » O-Ring Size: 2-224
- » O-Ring Groove ID: 1.73" (44 mm)
- » O-Ring Groove OD: 2.05" (52.1 mm)
- » O-Ring Groove Depth: 0.102" (2.6 mm)

OPERATING CONDITIONS

- » Max Operating Pressure: 80 psig (5.5 barg)
- » Max Operating Temperature for Inert Gas
842°F (450°C) without o-ring
212°F (100°C) with o-ring
- » Max Differential Pressure: 95 psid (6.5 bar)

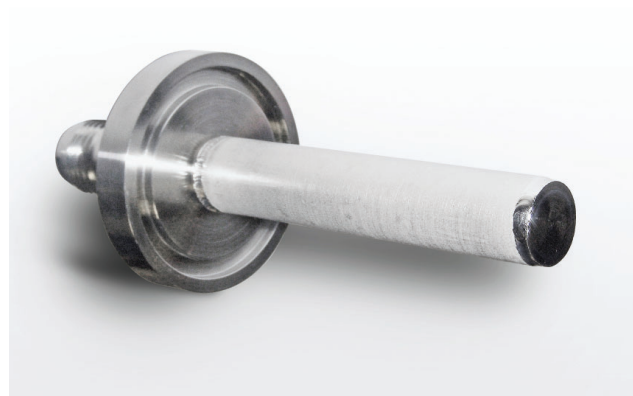

MATERIALS

- » Hardware: 316L SS
- » Filter Medium: 316L SS
- » Wetted Hardware Surface Finish: ≤ 10 Ra

SPECIFICATIONS

Particle Removal:	Confirmed down to 0.0015 μm
Particle Shedding:	Zero particle contribution above background (<1 particle/ft ³) per SEMIF43-0308 test method
Lifetime:	5 years or 3,000,000 cycles at max operating pressure (See warranty)

FLOW DATA

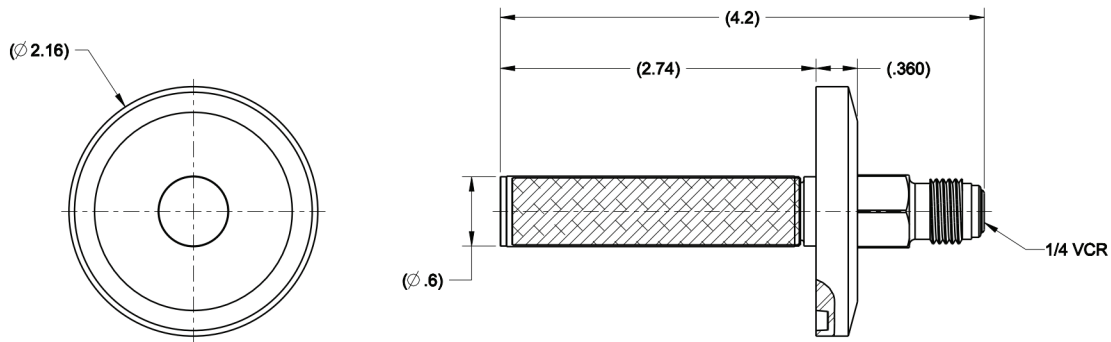
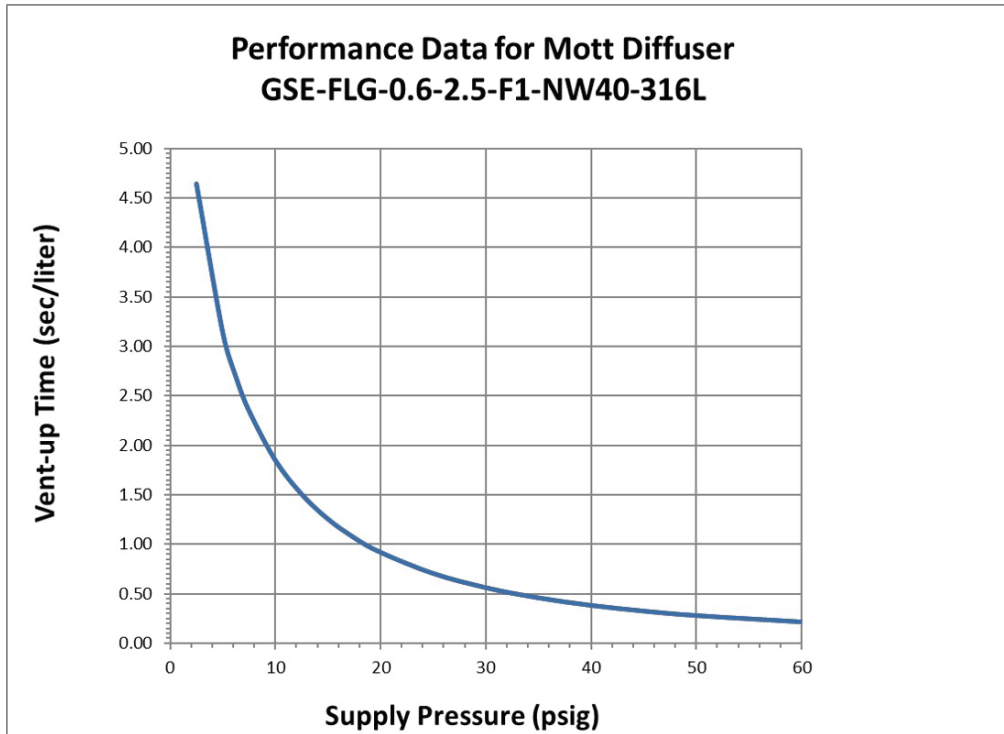

ORDERING INFORMATION

Part Description	Part Number	Fitting Type	Outlet Connections	Dimensions
GSE-FLG-0.6-2.5-F1-NW40-316L	6894040	1/4" Male Face Seal	ISO NW40 (Bulkhead mount with standard ISO bulkhead clamps)	See Drawing

*Custom designs and fittings available. Contact a Mott representative for more information.

WARRANTY

Mott Corporation ("Mott") warrants its GasShield diffuser will meet the specified retention and media integrity standards for a period of five years or 3,000,000 cycles whichever comes first from the date of purchase, providing the diffuser is properly installed and used in accordance with the specified flow, pressure, temperature, and chemical compatibility as published by Mott. Mott will replace or grant a purchase price refund for any GasShield diffuser which proves defective under the terms of this limited warranty. No other remedies apply. Mott disclaims all other warranties, either expressed or implied, including any warranty of merchantability or fitness for a particular purpose. Mott shall have no liability for consequential, incidental, special or punitive damages, lost profits or savings, or damages from lost production or damage to other materials.