

Porous Metal Products.

Continuous, particle-free gas
sampling, even in harsh extremes.

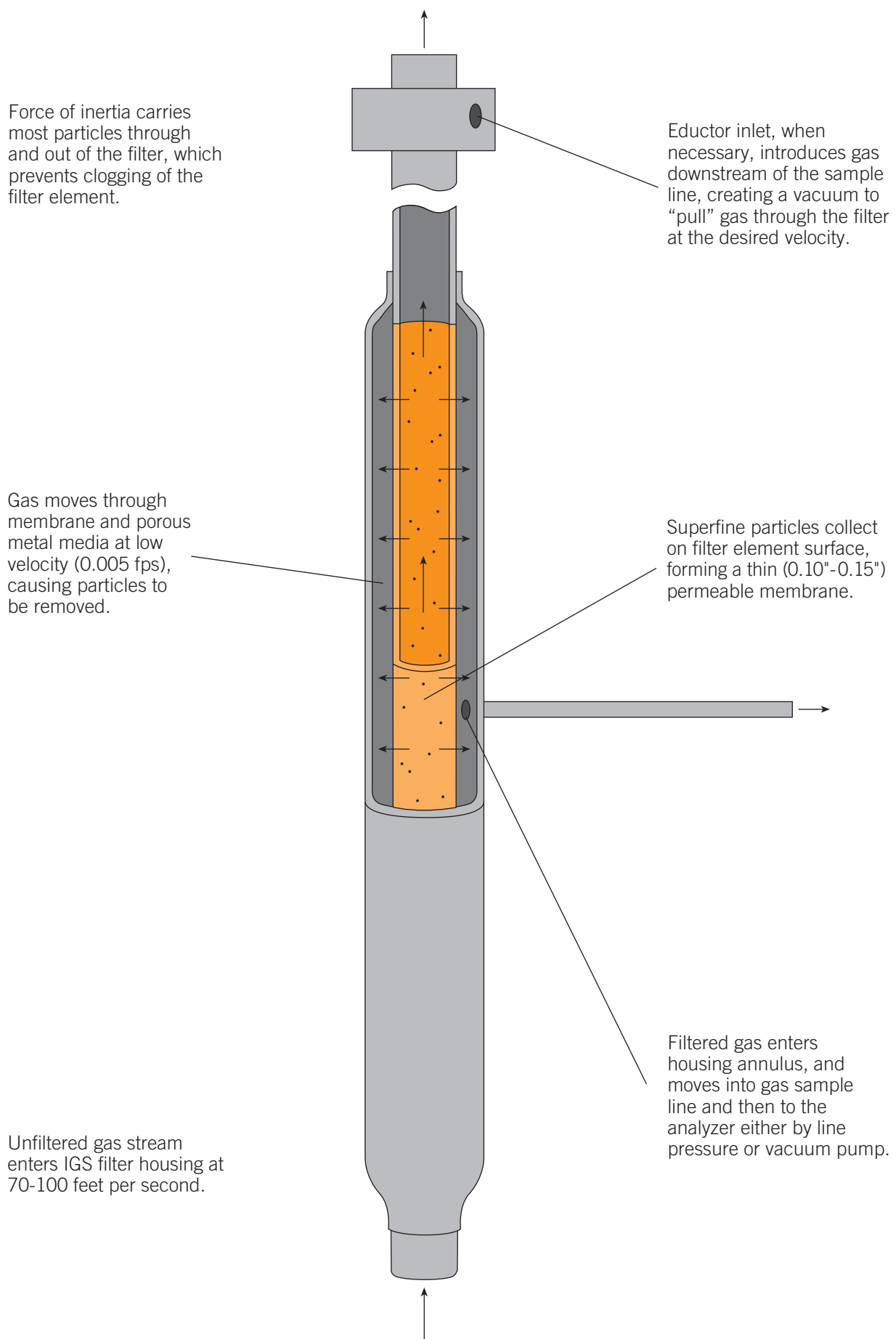

How Mott IGS filters work.



All-metal strength, plus cross-flow efficiency – the IGS approach to gas filtration.

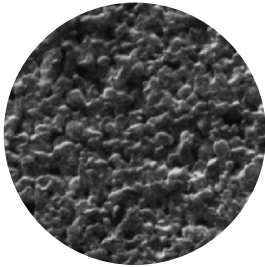

0.5µm (shown here, x100) is the recommended micrometer grade for most IGS filter applications. Mott also provides filters with all-metal media in 0.2µm, 2µm, 5µm and 10µm.

All-metal, inertial gas sampling (IGS) filters from Mott allow the collection of particle-free samples from virtually any gas stream, even those which are very hot or heavily contaminated. And, unlike other gas filters which may quickly plug and need to be thrown away, Mott IGS filters are designed to provide long-term – in many cases, permanent – filtration. Benefits of Mott's exclusive IGS design include:

Continuous, clog-resistant filtration. Mott IGS filters feature a cross-flow design which keeps most particles in the gas stream, greatly reducing obstruction of the filter element. As a result, Mott IGS filters can operate without clogging for great lengths of time, even when used with highly contaminated gas streams*.

Fast generation of high-purity samples. The high precision of Mott porous metal media, coupled with the development of a thin, dynamic membrane of superfine particles on the IGS filter element surface, effectively trap particles of all sizes, resulting in reliable, essentially particle-free gas sampling. Plus, IGS filters are designed with low internal volumes, so they produce fresh gas samples with minimal sample dwell times.

High temperature tolerance.

Depending on the material of construction, Mott IGS filters will withstand temperatures up to 1450°F/790°C in oxidizing atmospheres, and upto 1700°F/930°C in reducing or neutral atmospheres.

High corrosion resistance.

For applications involving corrosive gases, Mott IGS filters can be constructed of special high-strength materials such as Nickel, Hastelloy® and Inconel® alloys.

High pressure tolerance.

Unlike "soft" media, Mott porous metal can be used in high-pressure applications with differential pressures well in excess of 1000 psid.

Fast, efficient, in-situ cleaning.

If excessive particles are allowed to create a denser subsurface membrane on the filter element surface, removal can usually be achieved in seconds with a simple blowback – no shutting down, or removing the filter.

Wide selection of materials.

Mott offers the industry's widest array of metals and alloys to provide chemical compatibility for virtually any application. Standard construction generally consists of 316L stainless steel, but Mott filters can also be made from a variety of other metals, including Inconel®, Monel®, Alloy 20, and Hastelloy®.

Material Code	Material	Porous	Hardware	Flange
A	316L SS	+	+	+
B	316 SS	--	+	+
C	304L SS	+	+	+
D	304 SS	--	+	+
E	347 SS	+	--	--
F	300 Series SS	--	+	+
G	430 SS	+	--	--
H	Nickel 200	+	--	--
J	Monel® 400	+	+	+
K	Inconel® 600	+	+	+
L	Hastelloy® C276	+	+	+
M	Hastelloy® X	+	--	--
N	Alloy 20	+	+	+
P	Carbon Steel	--	--	+

+ Available
-- Not Economical

* In high moisture applications, temperature must be kept above dew point.

Material	Oxidizing	Neutral/ Reducing
316L SS (std)	750°F/400°C	1000°F/540°C
Inconel® 600	1100°F/590°C	1500°F/820°C
Hastelloy® X	1450°F/790°C	1700°F/930°C

Types of Mott IGS filters.

Model 7610 Filter Assembly.

Model 7610 is the basic Mott IGS filter, offered standard with a 0.5µm porous metal filter element, constructed of 100% 316L or 316 stainless steel, or with an Inconel® filter element within a 316 stainless steel housing. Filters with 0.5" ID, 12" or 24"-long filter elements are standard product and are normally in stock. Other sizes and materials are available upon request.

Model 7611 Standard External System.

The Model 7611 System consists of a Model 7610 IGS filter connected to an inline eductor. By locating the eductor downstream from the filter's gas sampling tube, gas or air may be introduced into the system to induce axial flow through the IGS filter element which achieves the necessary flow velocity through the IGS filter. This is generally required in low-pressure applications, where gas velocity would be below the minimum 70 fps needed for optimal IGS filter performance.

Model 7614 Flange-Mounted External System.

When access is limited to a horizontal vessel or duct, Model 7614 Systems allow installation of a complete, external IGS system by means of one 4" or 6" flange. Total external system width, including return piping, is 11.125". Standard materials for porous media, hardware, piping and flange are 316L, 300, and 304 series stainless steel. Others are available by request.



Model 7612 In-Stack System.

Model 7612 Systems allow placement of the IGS filter inside the stack or pipe, without risk of fouling the filter element, using a compact, self-contained filter/educator assembly. In-stack systems are often chosen because of external space limitations, or because an external system would drop the gas temperature below its dew point, requiring the addition of heat tracing to prevent condensation. Standard filter element lengths range from 6" to 72", constructed of 316L stainless steel or Inconel® 600.

Series 7600 Custom-designed Pipeline Systems.

Pipeline IGS systems allow installation of the IGS filter directly into the pipeline, eliminating the need for external mounting connections. Systems can be designed with threaded and flanged connections; the latter can also include a reduced ID system – a simple means to increase linear gas velocity without the use of an educator. Models can be used on pipes from 3/4" to 6" in diameter. Where in-pipe installation is not possible, Mott recommends using a bypass filter arrangement, as shown in the illustration.

Operating Parameters.

Recommended linear velocity in the pipeline is 70-100 fps, or as required to maintain proper velocity of entrained solids. See the accompanying Flow/Velocity Table below. Mounting may be horizontal or vertical.

Sample flow rate should be controlled to avoid premature filter plugging. Recommended sample flow rate is 30-60 cc/min/sq. in. of the inside surface of the filter tube.

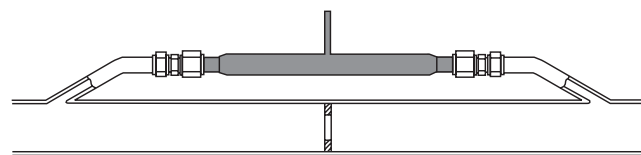
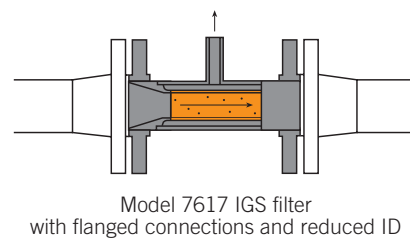
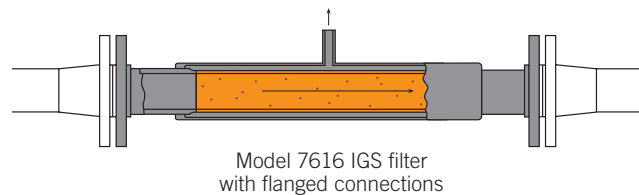
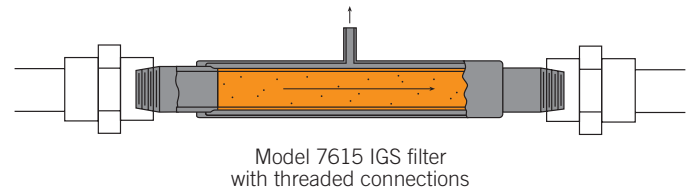
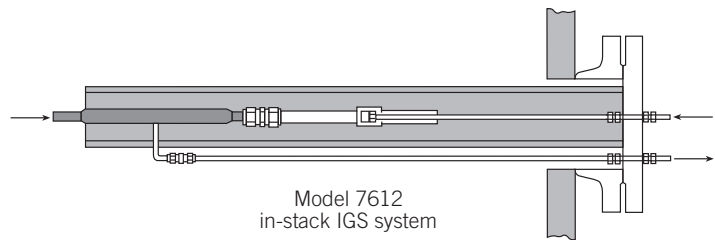

Flow/Velocity Table

Pipe Size (Sch. 40)	CFM@70FPS Axial Flow	CFM@100FPS Axial Flow
3/4	16	22
1	25	36
1 1/4	44	62
1 1/2	59	85
2	98	140
2 1/2	140	199
3	216	308
3 1/2	288	412
4	371	530
5	584	834
6	843	1204

Model 7610 – Filter

Specifications

Materials of Construction

- Standard – 316L SS Mott porous media 316 SS housing. Code AB.
- Inconel® 600 Mott precision porous media, 316 SS housing. Code KB.
- Hastelloy® X Mott precision porous media, 316 SS housing. Code MB.
- For other materials consult factory.

- All welded construction.
- Up to 1000 psi at 200°F.
- Catalog number: 7610-AA-BB-XX-DD
 7610 = IGS Filter Assembly
 AA = Element ID
 BB = Porous length
 XX = Standard media grade 0.5, 2
 DD = Material code Porous/Housing

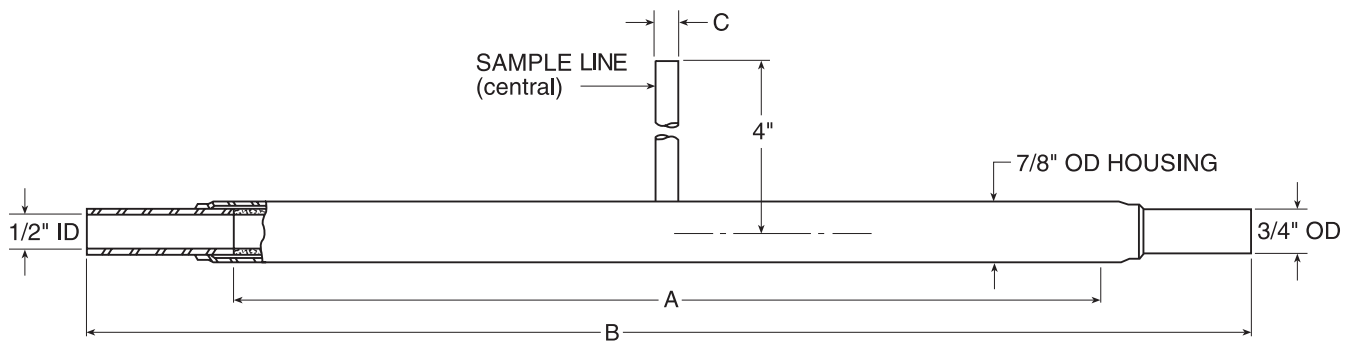

Part Description	Computer Part Number (CPN)	Sample Flow Liters/Minute Recommended/Max	A Porous Length	B Overall Length	C Sample Line Dia.
7610-½-6-XX-AB	7610100-XXX	0.5/1	6"	10"	¼"
7610-½-12-XX-AB	7610200-XXX	1/2	12"	16"	¼"
7610-½-24-XX-AB	7610450-XXX	2/4	24"	28"	⅜"
7610-½-36-XX-AB	7610650-XXX	3/6	36"	40"	⅜"
7610-½-48-XX-AB	7610750-XXX	4/8	48"	52"	⅜"
7610-½-60-XX-AB	7610850-XXX	5/10	60"	64"	⅜"
7610-½-72-XX-AB	7610951-XXX	6/12	72"	76"	⅜"

Examples: 7610-½-24-0.5-AB – IGS filter ½" ID x 24" porous length, 0.5 micrometer, 316L SS/316 SS.
 7610-½-12-2-MB – IGS filter ½" ID x 12" porous length, 2 micrometer, Hastelloy® X/316 SS.

Model 7611 – IGS Filter with Educator

Specifications

Materials of Construction

- Standard – 316L SS porous media, 316 SS housing and connector, 300 SS educator. Code (AB)F.
- Special – Inconel® 600 porous media, 316 SS housing and connector, 300 SS educator. Code (KB)F.
Hastelloy® X porous media, 316 SS housing and connector, 300 SS educator. Code (MB)F.
- For other materials consult factory.

- All welded construction, compression-type tube connector, no elastomeric seals.
- Up to 1000 psi at 200°F.
- Catalog number: 7611-AA-BB-XX-(DD)D
AA = Element ID
BB = Porous length
XX = Media grade 0.5 and 2
(DD)D = Material code (Porous/Housing and Connector)/Educator

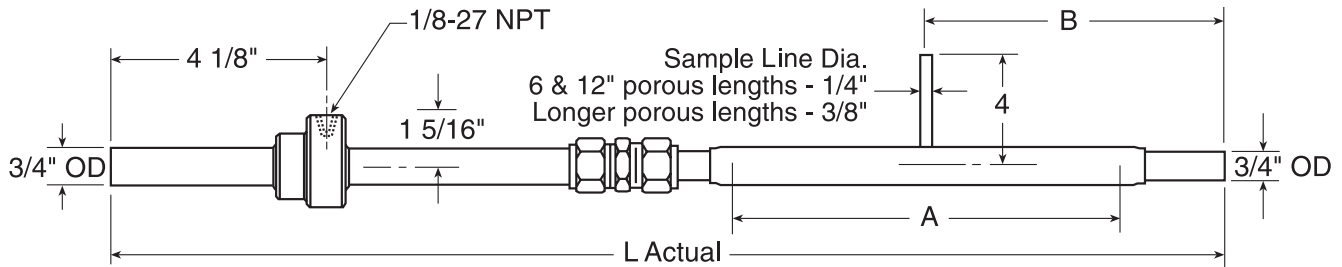

Part Description	Computer Part Number (CPN)	Sample Flow Liters/Minute Recommended/Max	A Porous Length	B	C Sample Line Dia.	L Length	Total Run Length
7611-½-6-XX-(AB)F	7611100-XXX	0.5/1	6"	5"	¼"	19.5"	2'
7611-½-12-XX-(AB)F	7611200-XXX	1/2	12"	8"	¼"	25.5"	2'
7611-½-24-XX-(AB)F	7611450-XXX	2/4	24"	14"	⅜"	37.5"	3'
7611-½-36-XX-(AB)F	7611650-XXX	3/6	36"	20"	⅜"	49.5"	4'
7611-½-48-XX-(AB)F	7611750-XXX	4/8	48"	26"	⅜"	61.5"	5'
7611-½-60-XX-(AB)F	7611850-XXX	5/10	60"	32"	⅜"	73.5"	6'
7611-½-72-XX-(AB)F	7611951-XXX	6/12	72"	38"	⅜"	85.5"	7'

Examples: 7611-½-24-2-(AB)F – external IGS system ½" ID x 24" porous length, 2 micrometer, 316L SS/316 SS/300 SS.
7611-½-12-0.5-(MB)F – external IGS system ½" ID x 1/2" porous length, 0.5 micrometer, Hastelloy® X/316 SS/300 SS.

Model 7614 – Flange Mounted External IGS System

Specifications

Materials of Construction

- Standard – 316L SS porous media, 316 SS housing and connector, 300 SS hardware, 304 SS flange. Code (AB)FD.
- Special – Inconel® 600 porous media, 316 SS housing and connector, 300 SS hardware, 304 SS flange. Code (KB)FD. Hastelloy® X porous media, 316 SS housing and connector, 300 SS hardware, 304 SS flange. Code (MB)FD.

■ All welded construction, compression tube connections.

■ Up to 1000 psi at 200°F.

■ Catalog number: 7614-F-AA-BB-XX-(DD)DD

F = Flange size 4" or 6"

AA = Element ID

BB = Porous length

XX = Media grade 0.5, 2

(DD)DD = Material code (Porous/Housing hardware/flange)

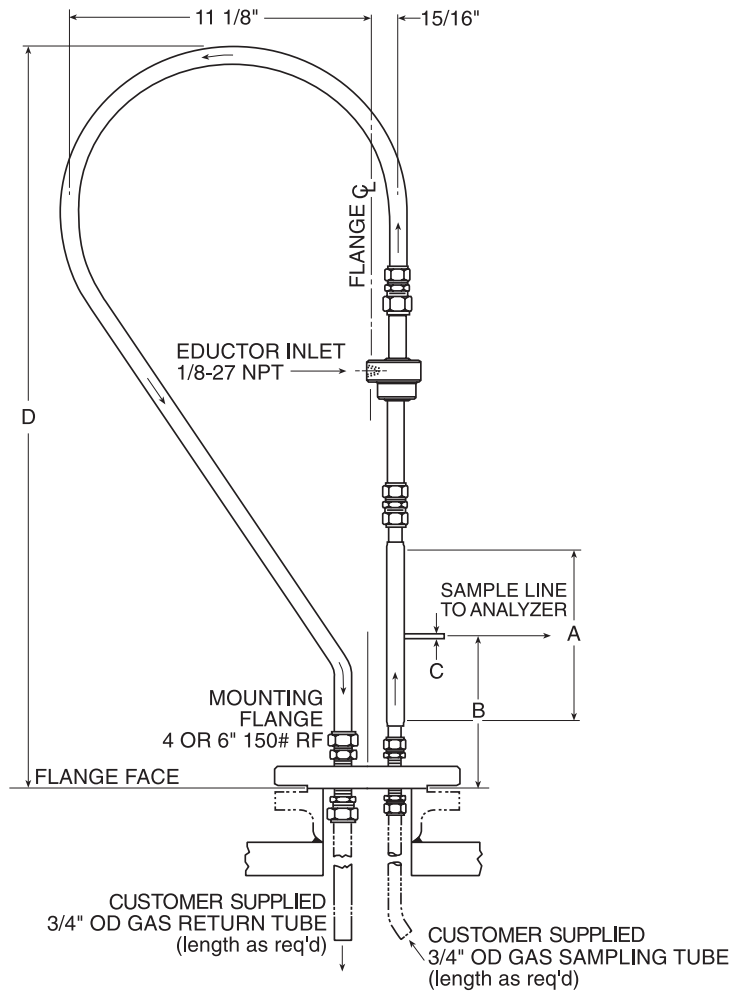

Part Description	Sample Flow Liters/Minute Recommended/Max	F Flange Size	A Porous Length	B	C Sample Line Dia.	D	Total Run Length
7614-4-½-6-XX-(AB)FD	0.5/1	4"	6"	6.5"	¼"	30.5"	6'
7614-4-½-12-XX-(AB)FD	1/2	4"	12"	9.5"	¼"	36.5"	7'
7614-4-½-24-XX-(AB)FD	2/4	4"	24"	15.5"	⅜"	48.5"	8'
7614-4-½-36-XX-(AB)FD	3/6	4"	36"	21.5"	⅜"	60.5"	10'
7614-4-½-48-XX-(AB)FD	4/8	4"	48"	27.5"	⅜"	72.5"	12'
7614-4-½-60-XX-(AB)FD	5/10	4"	60"	33.5"	⅜"	84.5"	14'
7614-4-½-72-XX-(AB)FD	6/12	4"	72"	39.5"	⅜"	96.5"	16'

Examples: 7614-6-½-24-0.5-(KB)FD – Flange-mounted IGS system with 6" mounting flange, ½" ID, 24" porous length, 0.5 micrometer, Inconel® 600/316 SS/300 SS/304 SS.
 7614-6-½-48-0.5-(MB)FD – Flange-mounted IGS system with 6" mounting flange, ½" ID, 48" porous length, 0.5 micrometer, Hastelloy® X/316 SS/300 SS/304 SS.

Model 7612 – In-Stack IGS System

Specifications

Materials of Construction

- Standard – 316L SS porous media, 316 SS housing and connector, 300 SS hardware, 304 SS flange. Code (AB)FD.
- Special – Inconel® 600 porous media, 316 SS housing and connector, 300 SS hardware, 304 SS flange. Code (KB)FD.
Hastelloy® X porous media, 316 SS housing and connector, 300 SS hardware, 304 SS flange. Code (MB)FD.

- All welded construction.
- Up to 1000 psi at 200°F.
- Catalog number: 7612-F-AA-BB-XX-(DD)DD
F = Flange size 4" or 6"
AA = Element ID
BB = Porous length
XX = Media grade 0.5, 2
(DD)DD = Material code (Porous, Housing), hardware, flange

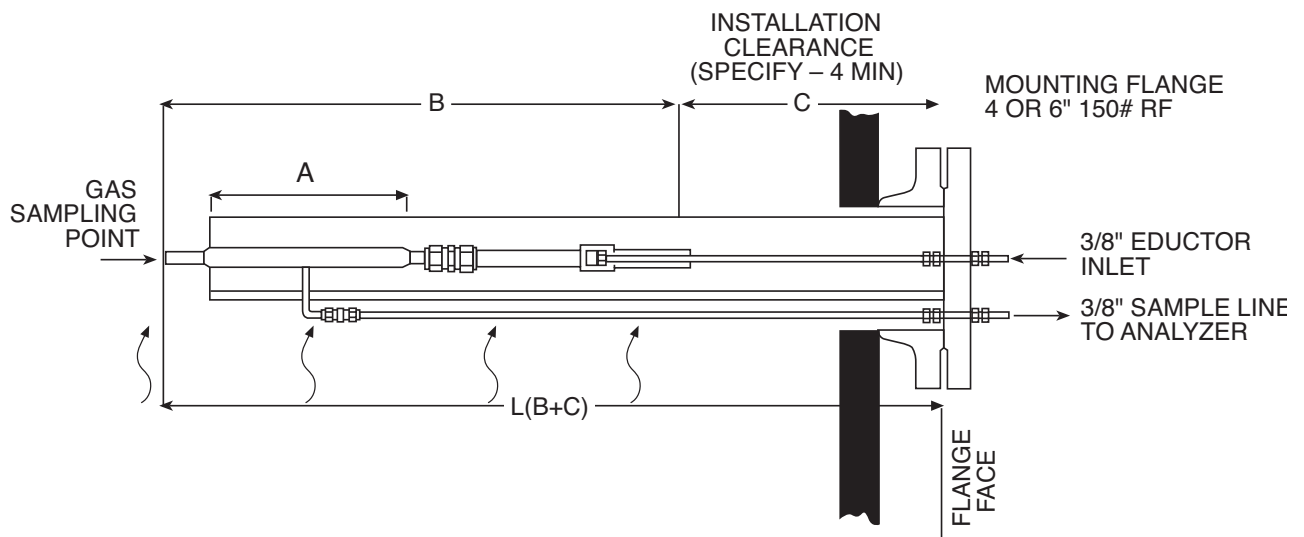

Part Description	Sample Flow Liters/Minute Recommended/Max	F Flange Size	A Porous Length	B	C Installation Clearance	L OAL Flange Face
7612-4-½-6-XX-(AB)FD	0.5/1	4"	6"	19.5"	*	**
7612-4-½-12-XX-(AB)FD	1/2	4"	12"	25.5"	*	**
7612-4-½-24-XX-(AB)FD	2/4	4"	24"	37.5"	*	**
7612-4-½-36-XX-(AB)FD	3/6	4"	36"	49.5"	*	**
7612-4-½-48-XX-(AB)FD	4/8	4"	48"	61.5"	*	**
7612-4-½-60-XX-(AB)FD	5/10	4"	60"	73.5"	*	**
7612-4-½-72-XX-(AB)FD	6/12	4"	72"	85.5"	*	**

* Specify clearance - 4" minimum

** L = B + C

Examples: 7612-4-½-24-2-(AB)FD, 18" installation clearance – In-Stack IGS system with 4" mounting flange, ½" ID, 24" porous length, 2 micrometer, 316L SS/316 SS/300 SS/304 SS.
7612-4-½-12-0.5-(MB)FD, 18" installation clearance – In-Stack IGS system with 4" mounting flange, ½" ID, 12" porous length, 0.5 micrometer, Hastelloy® X/316 SS/300 SS/304 SS.

Mott IGS System Design Parameters

1. Determine process operating data for gas sampling application. Sample flow rate (liters/min.), gas temperature, gas dew point, characterize solids, solids loading, operating pressure.
2. Select porous length, based on required sample flow rate. (If near maximum, recommend use of next longer model.)
3. Select material based on gas temperature and/or corrosion requirements.
4. Select IGS model depending on application needs.

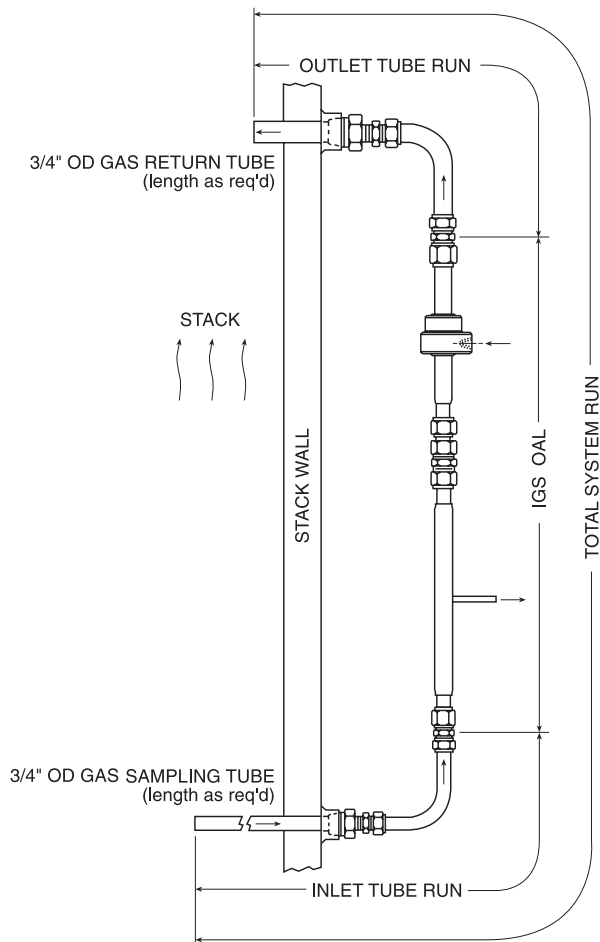

Typical 7611 IGS external system arrangement

5. To establish eductor operating criteria:
 - a) Estimate system run in feet:
 Model 7611 total run length, plus inlet tube run, plus outlet tube run.
 Model 7612 use system run of 10 ft.
 Model 7614 total run length, plus length of sampling and return tubes.
 - b) Determine eductor supply pressure, (Fig. 1). Enter system run on horizontal axis. Move up to intersect the 85 FPS curve, move to left and read eductor supply pressure.
 - c) Determine eductor gas flow, (Fig. 2). Enter eductor supply pressure on vertical axis. Move right to intersect curve. Move down and read eductor gas flow.
6. Determine sample vacuum. At recommended maximum sample flow rates, vacuum required is nominally 10-20" H₂O at the sample line. Higher vacuums may be required depending on application conditions; line losses to the analyzer must be considered.

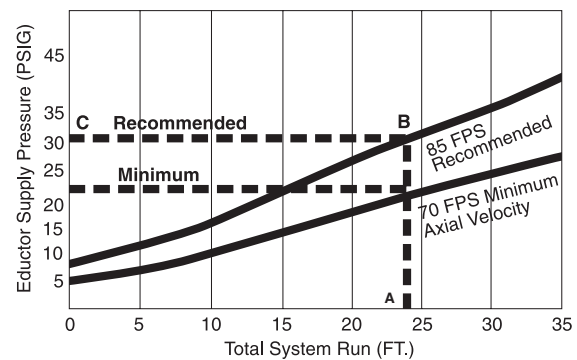

Fig. 1. Determination of eductor supply pressure

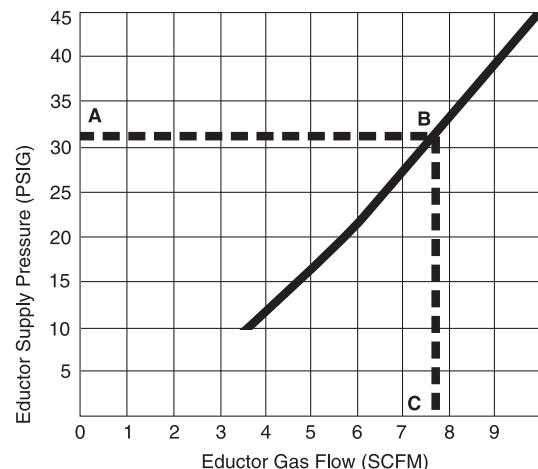
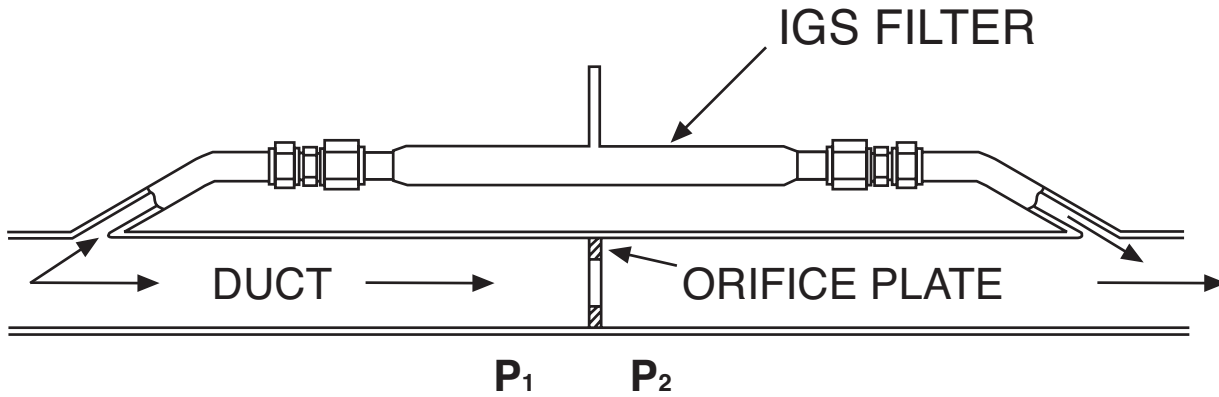

Fig. 2. Determination of eductor gas flow

IGS Notes

Bypass Filter Arrangement



For sampling in positive-pressure systems from large ducts or pipes, such as an FCC catalyst regenerator stack, a model 7610 IGS filter can be used without an eductor. The filter is mounted across an orifice plate that produces a minimum of a 2 psi differential across the filter, which will generate the required axial velocity in the filter. Smooth piping transitions into and out of the filter should be used to prevent solids from settling out.

Clean Gas Sample Flow Control

For maximum service life with IGS filters it is recommended that the clean sample flow rate be controlled to the required flow rate using control valves or other methods. This will assure minimum plugging and long on-stream life.

Replacement Parts

To order standard connectors and eductors as replacements or spare parts, use the part numbers listed. Standard connector material is 316 SS; standard eductor material is 300 Series SS. Other materials available. Consult the factory.

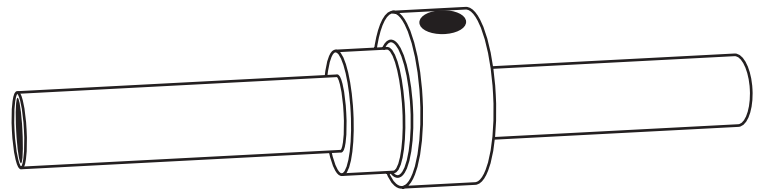

Eductor P/N 100226-09

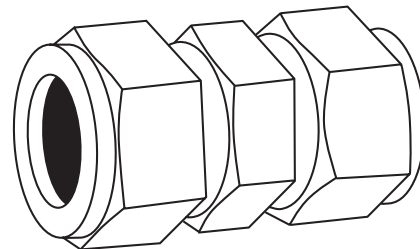

Connector P/N SS-1210-6

Where Mott IGS filters are used.



By virtue of their design and breadth of choice, Mott IGS filters are well suited to a variety of gas sampling applications. Here are three specific examples based on recent installations, followed by a list of other typical IGS uses.

Fluid Catalytic Crackers.

To help maintain productivity, CO and CO₂ levels are monitored in flue gases coming from catalyst regenerators in fluid catalytic crackers. The gases are sampled after they pass through a waste heat boiler, prior to entering a cyclone and pass-ing out the stack, where the particle load is heavy, and temperatures remain constant at 450°F. A Mott IGS Model 7611 Filter System, insulated to prevent condensation, has operated continuously in one such application for more than 6 months with no need for maintenance.

Lime Kilns.

Reliable O₂ analysis is required in dry process preheater lime kilns to reach maximum fuel efficiency, to maintain an oxidizing atmosphere for consistent product quality, and to ensure combustibles are kept out of the process gas. At the sampling point in the back end of the kiln, gas temperatures range from 1700°F to 2000°F, and contamination is heavy. A Mott IGS Model 7611 filter with an Inconel porous metal element has been configured with an exposed inlet tube to drop the temperature below 1000°F, resulting in continuous service for more than a year without replacement.

Utility Coal Pulverizers.

A coal pulverizer for a utility boiler may process up to 60 tons of coal per hour – an environment that is very vulnerable to fire, requiring the fastest possible detection in order to “inert” the system quickly. One method is to use thermocouples, but they do not react until a fire has started and causes a rise in temperature. CO analyzers provide a faster response, but are sensitive to dirty environments which may also clog conventional gas filters. A Mott IGS Model 7614 filter provides the ideal solution, and in a recent installation has operated for over a year with minimal maintenance.

Other typical Mott IGS sampling applications.

- Open hearth steel furnaces
- Sulfur plant off-gas incinerator stacks
- Boiler flue gas for combustion control and emission monitoring
- Coking oven off-gas atmospheres
- General process control and emission control monitoring

mott
MISSION CRITICAL PRECISION

Hastelloy is a registered trademark of Haynes International, Inc.

Inconel and Monel are registered trademarks of Special Metals Corporation

84 Spring Lane, Farmington, CT 06032-3159 | 860-747-6333 Fax 860-747-6739
www.mottcorp.com | email: info@mottcorp.com