

Mott HyPulse® HyLine Filters

Inline Filters – Mott Porous Metal Media

Batch Process and Small Process Separation
of Solids from Liquid or Gases



Mott HyPulse® HyLine Porous Metal Filters

Mott HyPulse HyLine Filters use elements made of Mott precision porous metal media, which allows automated, insitu backwash/blowback cleaning. When applied according to Mott recommendations, element life is generally measured in terms of months or years. The standard media material is 316L stainless steel which is suitable for service with most chemicals, even at temperatures that would destroy a non-metal filter in seconds. Other materials include Hastelloy®, Monel®, Nickel, Inconel®, Alloy 20, and Titanium. Proprietary production techniques make Mott precision porous metal media unequalled in uniformity and performance. Standard media grades range from 0.2 to 100.

High-Integrity Design

Each Mott HyPulse HyLine Filter is individually pressure tested, as a unit, at 1.5 times its rated capacity. Housings are made of 316L stainless steel and feature a single O-ring seal design to provide strength and dependability. The element has a 1" NPT pipe thread connection which eliminates gaskets and the possibility of leakage around them. Each filter element is individually tested for flow uniformity and bubble point integrity. Standard features include a 1" drain for backwash or blowback cleaning with a built-in option of a ¼" drain. Integral ¼" differential pressure taps are standard.

Application Versatility

The Mott HyPulse HyLine Filter can separate solids from liquids and gases in a wide variety of applications. Uses range from a simple final downstream protection filter to a small-scale or pilot-plant process filter. Available accessory kits and a choice of housings and elements make tailoring the HyPulse HyLine to your application easy.

High Limits

HyLine models are available in 250 psi, and 1000 psi ratings at 400°F / 204°C. Mott multi-tube filter elements are suitable for differential pressures of up to 1000 psi. Higher temperatures can be accommodated by use of an Inconel housing seal ring rather than an elastomeric o-ring.

Features and Benefits

- Heavy-duty 316L stainless steel construction
- Threaded element connection
 - Eliminates gasket seals
 - Prevents gasket seal bypass
- Inline piping connection
 - Allows element removal without breaking inlet/outlet connections
- Large 1" NPT drain
 - Includes ¼" NPT plug
- Single O-ring housing seal
 - Wide material selection
 - Temperatures to 400°F / 204°C
- Two pressure ranges
 - 250 psi, 1000 psi
- Two element lengths
 - 9 in., 29 in.
- Three element diameters
 - 1½", 2", 2½"
 - Provides application flexibility
- Multitube elements available
 - Allows differential pressure to 1000 psi
- Spring reinforced elements available
 - Consult factory for differential pressure ratings
- Operates in any position
- Differential pressure taps are standard
 - ¼" NPT
- Operating valve kits are available

Applications

- Liquids/Steam/Air/Gases
- Process filter
- Sampling filter
- Polishing filter
- Point-of-use filter
- Pilot or test filtration
 - Feasibility
 - Filterability
 - Flow vs. Delta P
 - Efficiency
 - Backwash capability
 - Cake characterization
 - Cake-holding capacity
 - Precoat performance
 - Optimize filter operation parameters

Pilot Plant Process Applications

The Mott HyPulse® HyLine, when used with the Backwash/Blowback Valve Kit, is especially useful for pilot plant use. Data from the pilot plant operation can be used to specify and/or design full-scale Mott HyPulse process filters. The HyPulse HyLine filter can be used to evaluate feasibility, filterability, efficiency, flow versus differential pressure, backwash or blowback capability, cake-holding capacity, cake characterization, cycle time, throughput, precoat performance (if used), and to optimize operating parameters.

Filter Flow Ratings

LIQUID/SOLIDS APPLICATIONS HIGH-EFFICIENCY FILTRATION – INSITU BACKWASH

Use 2" diameter elements—media grades 0.2, 0.5, 2, 5
(1½" diameter elements for maximum cake capacity)
Filtration (flux) rates from 0.2 to 1 GPM/Ft²

ELEMENT DIAMETER	FLOW RATE GPM/SQ. FT.	FLOW RATES GPM	
		9"	29"
2"	0.2	0.08 GPM	0.24
	0.5	0.21	0.63
	1.0	0.43	1.29
1½"	0.2	0.06	0.19
	0.5	0.16	0.49
	1.0	0.32	0.98

POLISHING FILTRATION

Use 2½" diameter elements

FLOW RATES GPM – 1 CPS – 2 PSI CLEAN PRESSURE DROP

ELEMENT DIAMETER	MEDIA GRADE	ELEMENT LENGTH	
		9"	29"
2½"	0.2 & 0.5	0.3	0.9
	2	1.3	4.0
	5	2.2	6.6
	10	8.0	11.0
	20	12.0	13.5
	40 & 100	13.5	14.0

GAS/SOLIDS APPLICATIONS HIGH-EFFICIENCY – INSITU BLOWBACK

Use 2" diameter elements—media grades 2, 5, 10
(1½" diameter may be used for maximum cake capacity)
Filtration (flux) rates from 2-10 FPM (ACFM/Ft²)

ELEMENT DIAMETER	FLOW RATE FPM	FLOW RATES ACFM	
		9"	29"
2"	2	0.9 ACFM	2.6
	5	2.1	6.5
	10	4.3	13.0
1½"		0.6	
		1.6	
		3.2	

FINAL TRAP FILTRATION

Use 2½" diameter elements

FLOW RATES SCFM – @100 PSIG – 2 PSI CLEAN PRESSURE DROP

ELEMENT DIAMETER	MEDIA GRADE	ELEMENT LENGTH	
		9"	29"
2½"	0.2 & 0.5	13 SCFM	39
	2-100	100	100

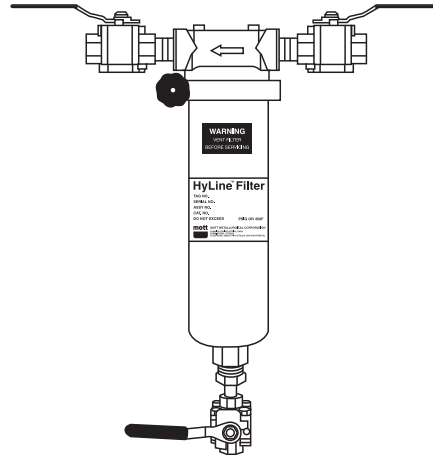

BASIC VALVE KIT
K77B-12 ¾" NPT
K77B-16 1" NPT

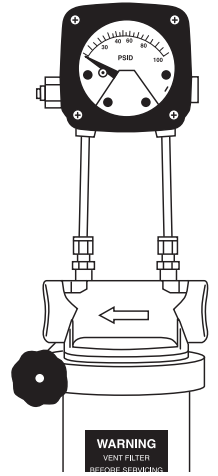

DIFFERENTIAL PRESSURE GAUGE KIT
K77A

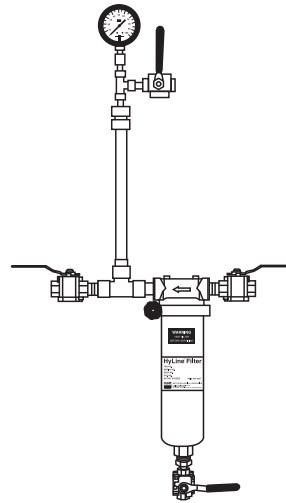

BACKWASH VALVE KIT
K77C-16 1" NPT

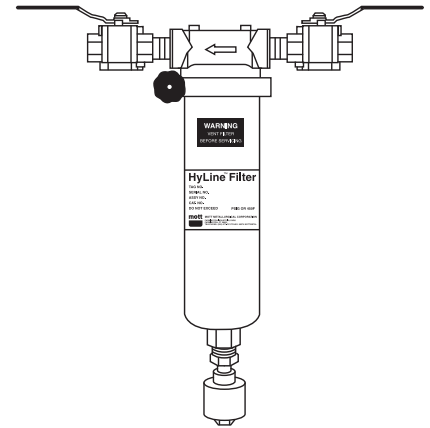

STEAM FILTER KIT
K77D-12 ¾" NPT
K77D-16 1" NPT

HyPulse® HyLine Series 7700

Ordering Information

Order by Housing/Element

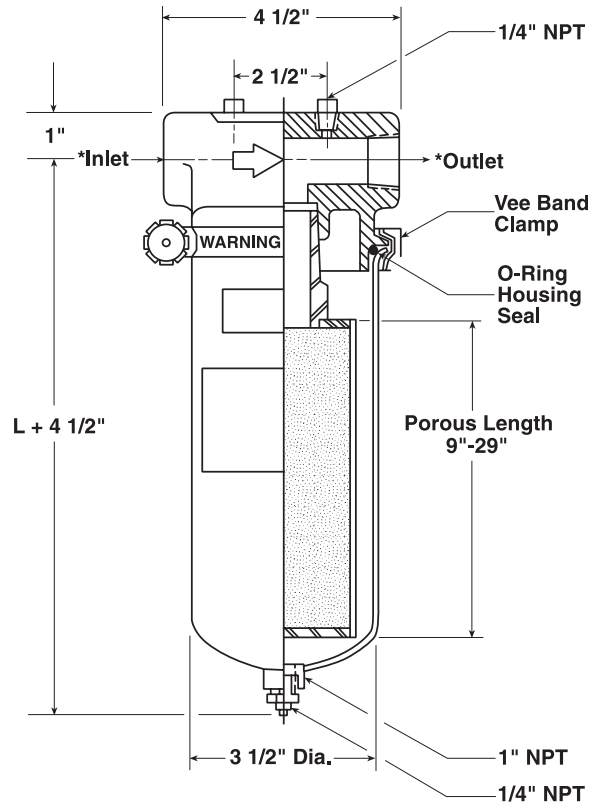
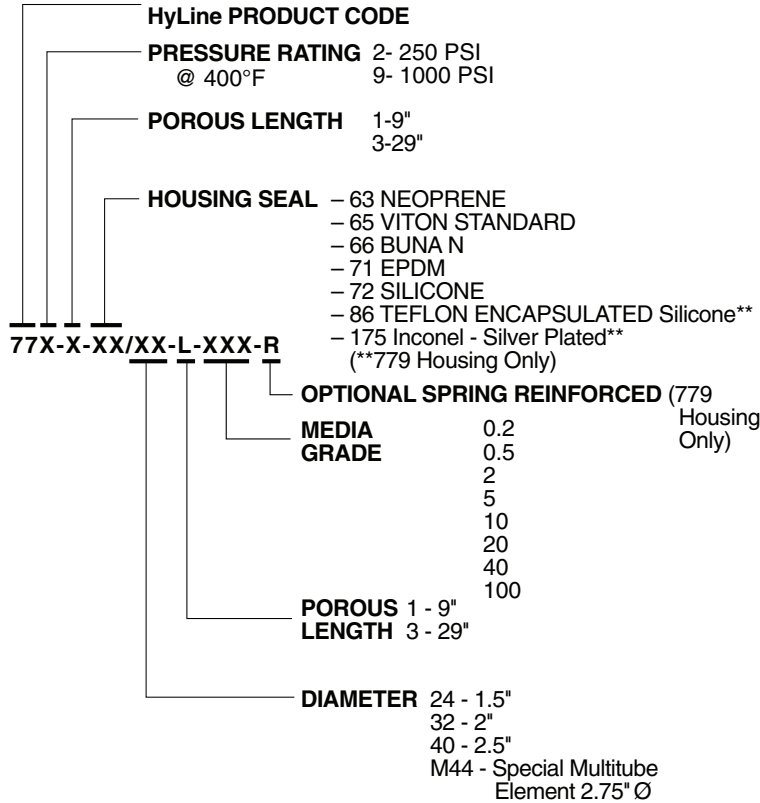

EXAMPLES Housing / Element:

779-1-72/40-1-0.2-R

1000 PSI housing – 9" lg – Silicone seal/2½" dia. –
9" lg – Media Grade 0.2 – spring reinforced element

772-3-66/32-3-2

250 PSI housing – 29" lg – Buna N seal/2" dia. –
29" lg – Media Grade 2 element

779-3-86/24-3-20

1000 PSI housing – 29" lg – Teflon encapsulated silicone seal/
1½" dia. – 29" lg – Media Grade 20 element

For replacement elements, see next page.

* 10" housing – ¾" NPT inlet/outlet
30" housing – 1" NPT inlet/outlet

Cylindrical Elements

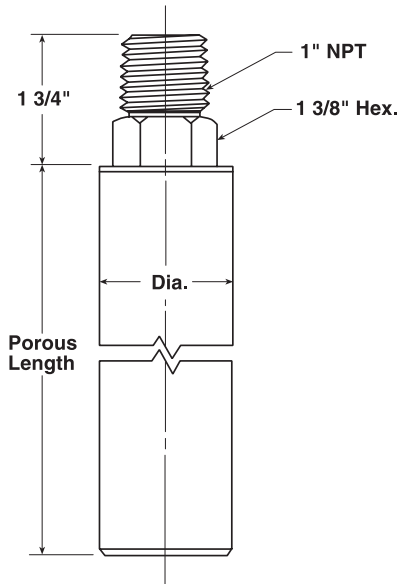

Part Description	
77/XX-X-XX-R	OPTIONAL SPRING REINFORCED
	MEDIA GRADE
	- 0.2 - 10
	- 0.5 - 20
	- 2 - 40
	- 5 - 100
	POROUS LENGTH
	- 1 9"
	- 3 29"
HyLine PRODUCT CODE	DIAMETER
	- 24 1.5"
	- 32 2"
	- 40 2.5"

Filter Area

10" Housing (9" Porous)
 1.5" Dia Element - 0.3 Ft²
 2.0" Dia Element - 0.4 Ft²
 2.5" Dia Element - 0.5 Ft²

30" Housing (27" Porous)
 1.5" Dia Element - 0.9 Ft²
 2.0" Dia Element - 1.2 Ft²
 2.5" Dia Element - 1.5 Ft²

Multitube Elements (7 Tube Filter)

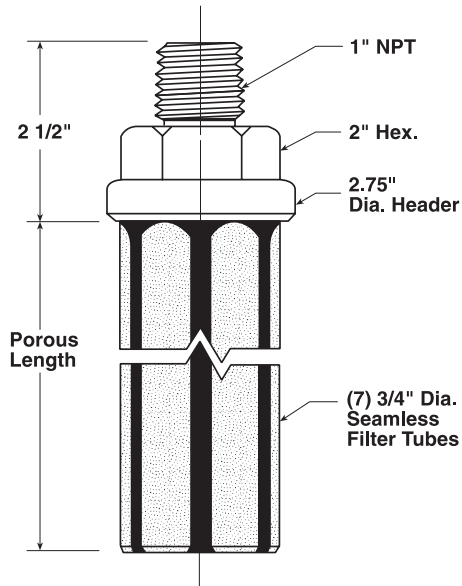

Part Description	
77/M44-X-XX	MEDIA GRADE
	- 0.2
	- 0.5 - 10
	- 2 - 20
	- 5 - 40
	POROUS LENGTH
	- 1 9"
	- 3 27"
	2.75" DIA. HEADER
	HyLine PRODUCT CODE

Filter Area

10" Housing (9" Porous) - 1.0 Ft²
 30" Housing (27" Porous) - 3.2 Ft²

mott corporation

84 Spring Lane, Farmington, CT 06032-3159
 www.mottcorp.com, email: quest@mottcorp.com
 860-747-6333 Fax 860-747-6739